

# Model K-01A Twin Level Harp Rack

- \* 30 Slots At 9/16" On Each Level
- \* 5" Caster, 2 Swivel, 2 Rigid
- \* 1 Floor Lock
- \* Paint: Kear Green

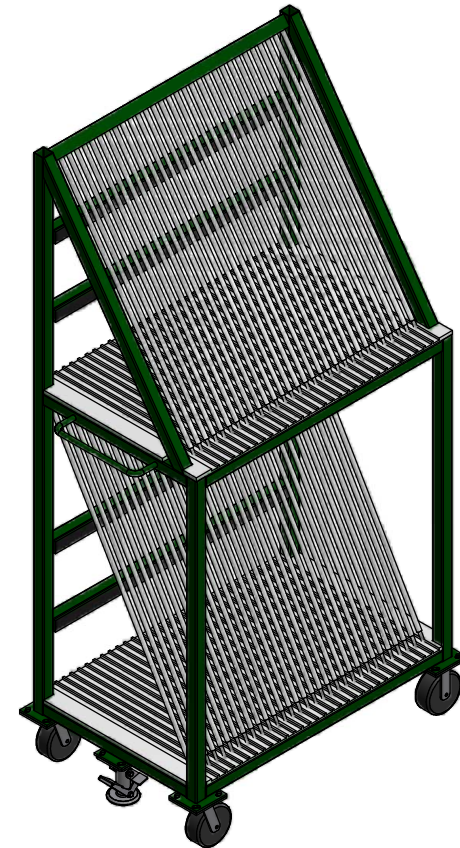
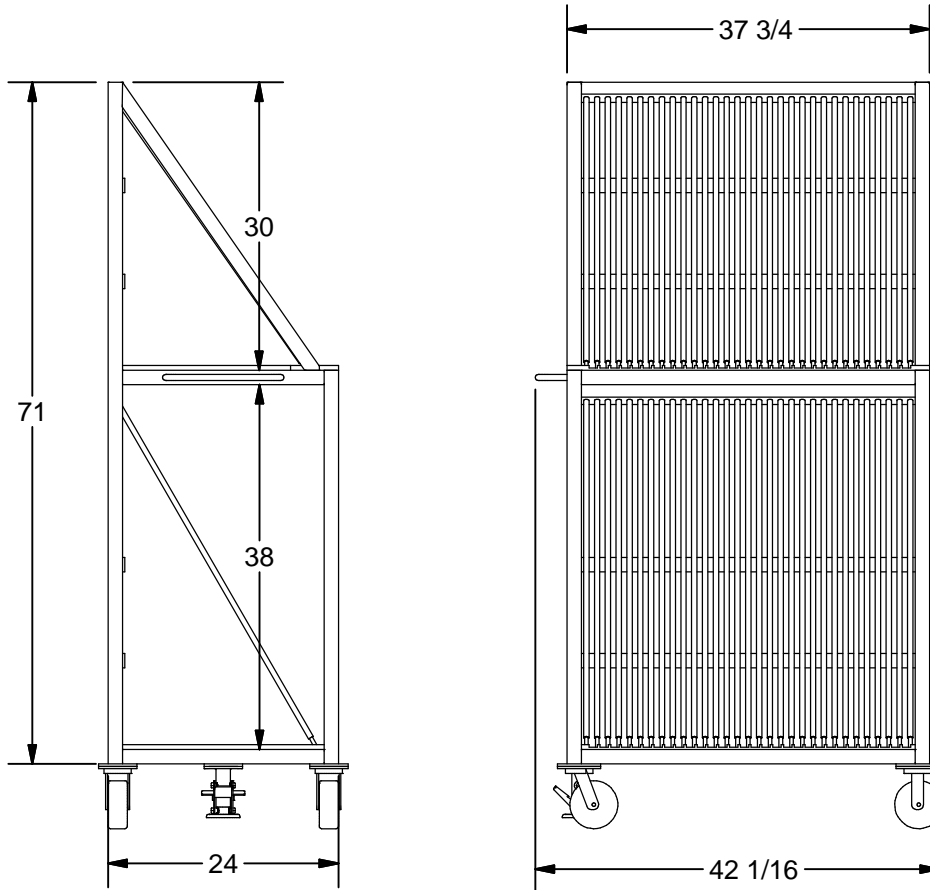

**K E A R** FABRICATION INC.  
27 Vanley Crescent, North York, ON, M3J 2B7 - Tel: (416) 398-8666 - Fax: (416) 398-9666

This drawing is property of Kear Fabrication Inc. and may not be copied or modified without the express consent of Kear Fabrication Inc. All dimensions are in inches and are accurate to 1/16". Angles are accurate to 1/2°. Report all changes and/or errors to the Kear Fabrication Inc. Engineering Department.