

# Model K-32TT Draw System

- \* 15 Draws With 5" Ledge  
Glass Size 96" x 130"
- \* 5 Drawing With 7"  
Glass Size 72" x 96"
- \* Paint : Kear Green

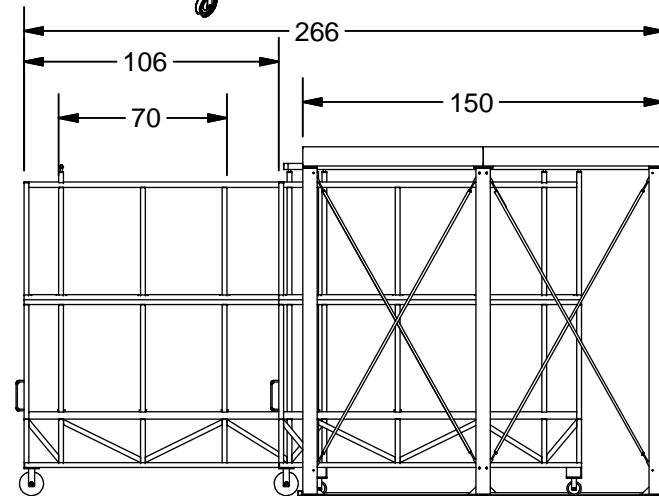
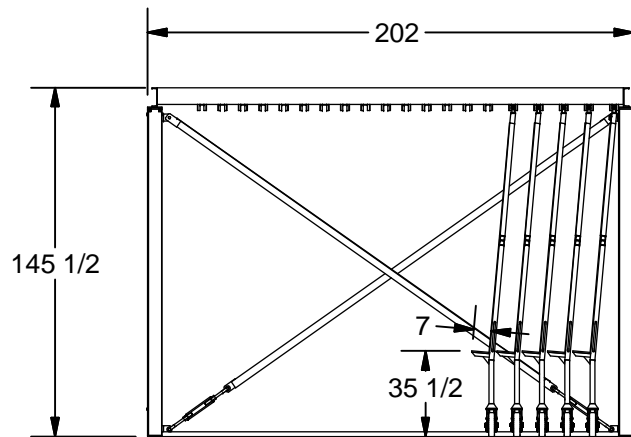
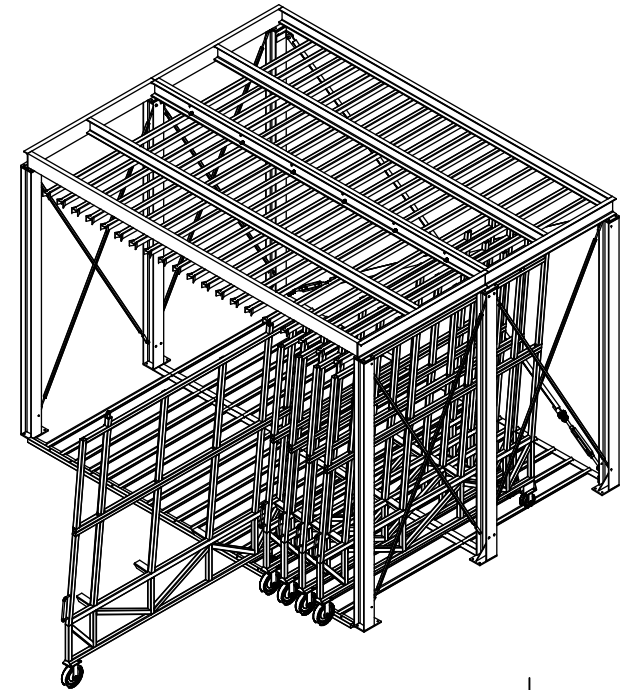

Title: Over View		Drawn By: Tony Yan		This drawing is property of Kear Fabrication Inc. and may not be copied or modified without the express consent of Kear Fabrication Inc. All dimensions are in inches and are accurate to 1/16". Angles are accurate to 1/2°. Report all changes and/or errors to the Kear Fabrication Inc. Engineering Department.	<b>Kear Fabrication Inc.</b> 27 Vanley Crescent North York, ON, Canada M3J 2B7 Tel: (416) 398-8666 Fax: (416) 398-9666
File Name: Primary R1	Job #:	Date: 03/01/2011			
Customer:		Checked By:			
Description: K-32TT Draw System		Date:			
		Scale: NTS	Sheet #: 1 of 1		