

K-29P Stretch Wrap Machine - Pneumatic

* Work Size: Max. 68" and High min. 28" max.98"

* Paint: Kear Green

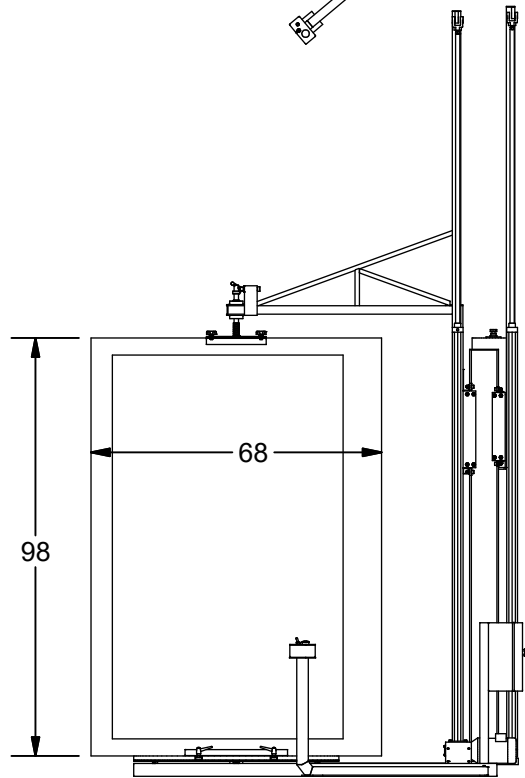

Notice: Jig will do later
We need Draws of frame
or provide material for test

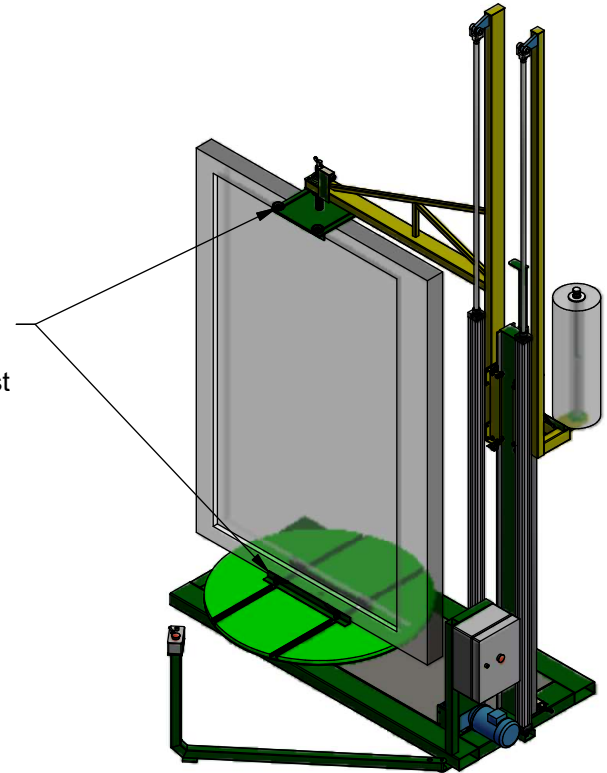

K E A R F A B R I C A T I O N I N C.

27 Vanley Crescent, North York, ON, M3J 2B7 - Tel: (416) 398-8666 - Fax: (416) 398-9666

This drawing is property of Kear Fabrication Inc. and may not be copied or modified without the express consent of Kear Fabrication Inc. All dimensions are in inches and are accurate to 1/16". Angles are accurate to 1/2°. Report all changes and/or errors to the Kear Fabrication Inc. Engineering Department.