

# K-11STGI IG Shipping Rack

- base 45" depth overall x 63.375" wide x 67" overall high
- 3/4" Thick HDPE. Slotted
- 3 Rows of hooks on bottom rail
- 52 Slots at 7/8" slot wide
- 90 degrees lean back.
- Include Corner clip & cord.
- Forklift excess all 4 sides.
- Paint: blue

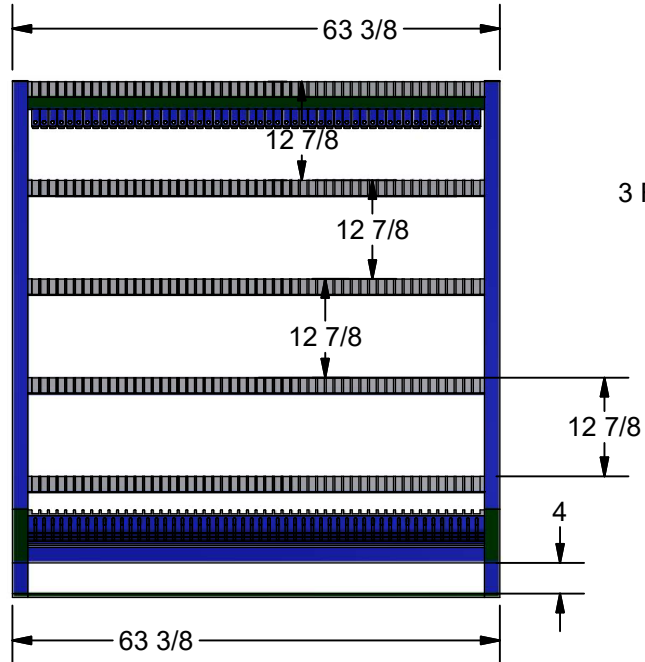

We add 1 more strip to support the small glass

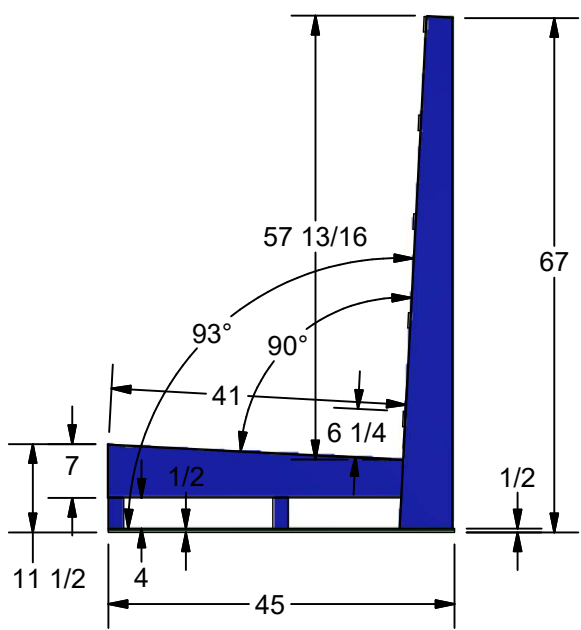
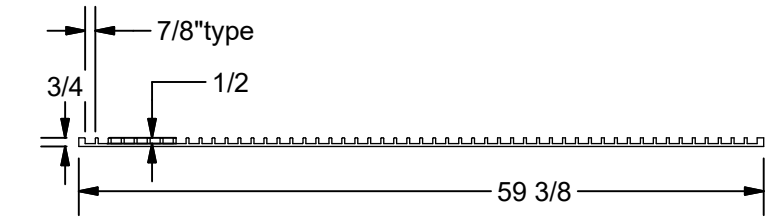
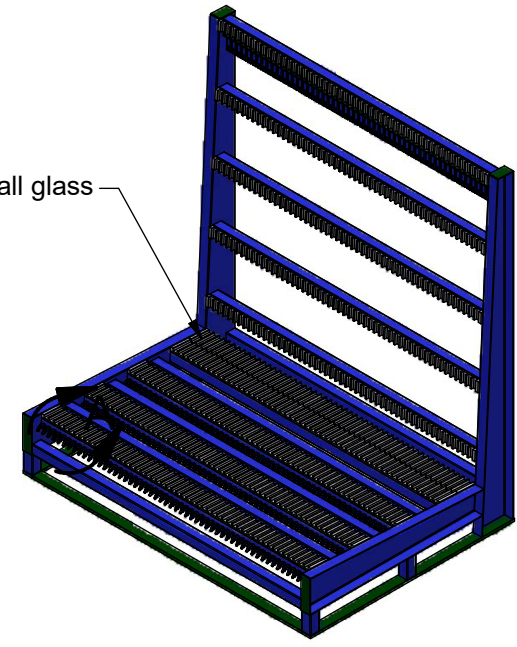

3 Rows of hooks

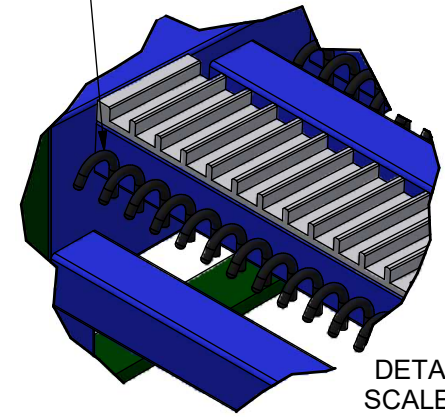

DETAIL A  
SCALE 1 / 6

**K E A R FABRICATION INC.**  
27 Vanley Crescent, North York, ON, M3J 2B7 - Tel: (416) 398-8666 - Fax: (416) 398-9666

This drawing is property of Kear Fabrication Inc. for Purpose of customer approval only. Any dimensions, materials, parts and paint not shown in the drawing are pending to standards and design of Kear Fabrication Inc.

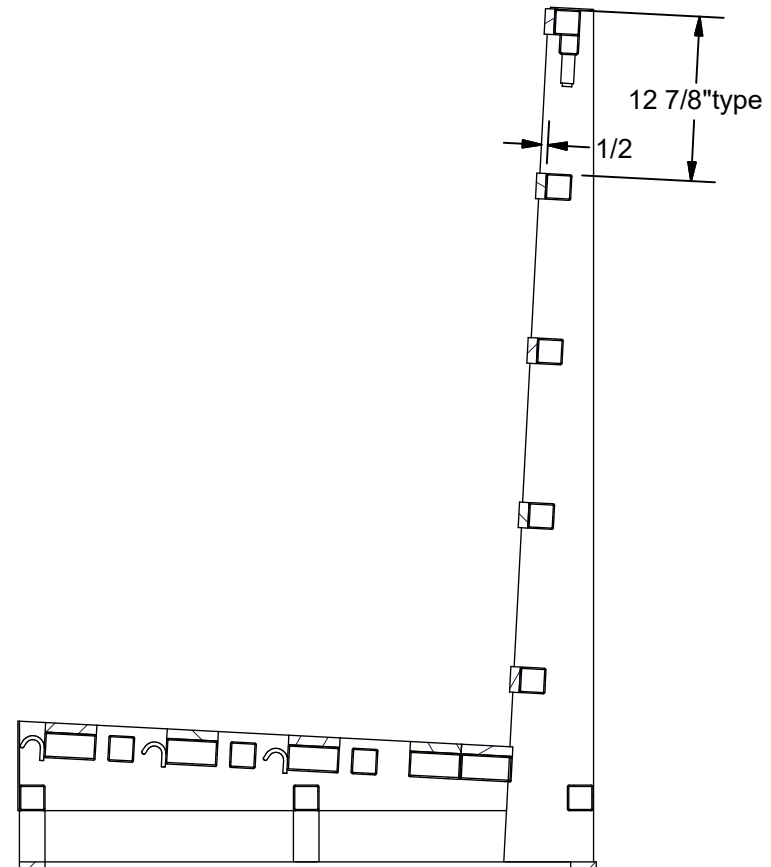
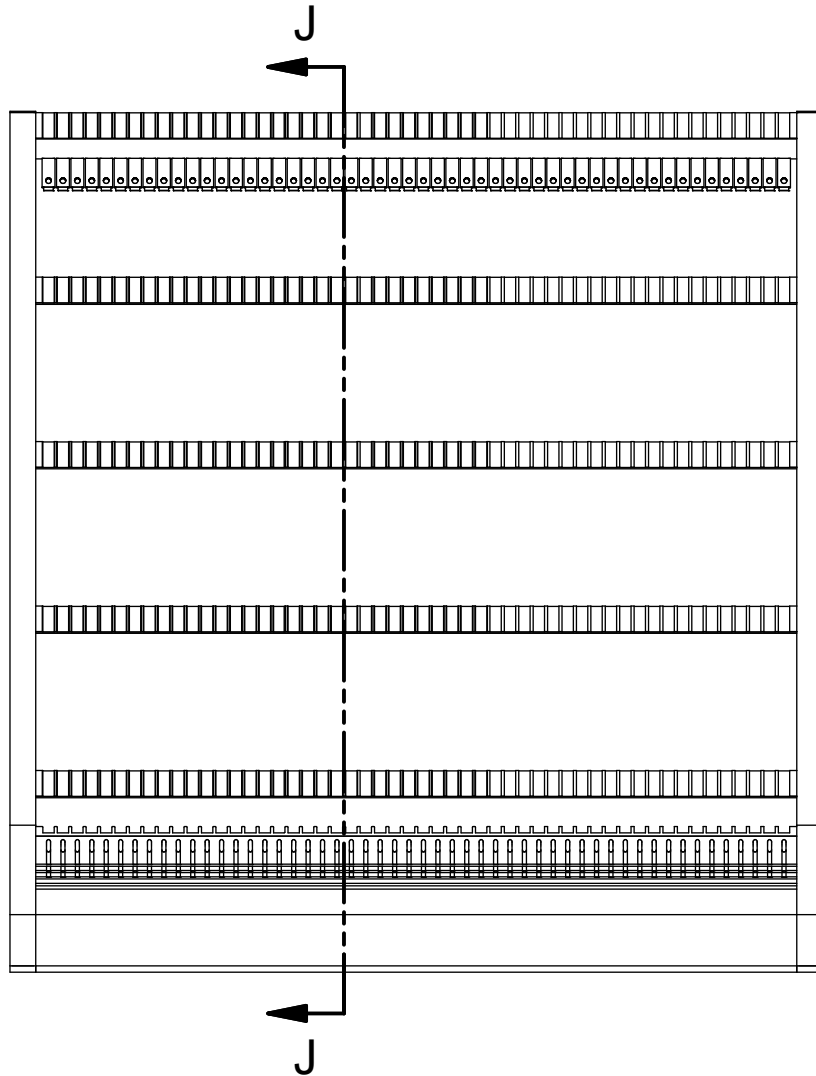

SECTION J-J  
SCALE 1/15

**K E A R** FABRICATION INC.  
27 Vanley Crescent, North York, ON, M3J 2B7 - Tel: (416) 398-8666 - Fax: (416) 398-9666

This drawing is property of Kear Fabrication Inc. for Purpose of customer approval only. Any dimensions, materials, parts and paint not shown in the drawing are pending to standards and design of Kear Fabrication Inc.

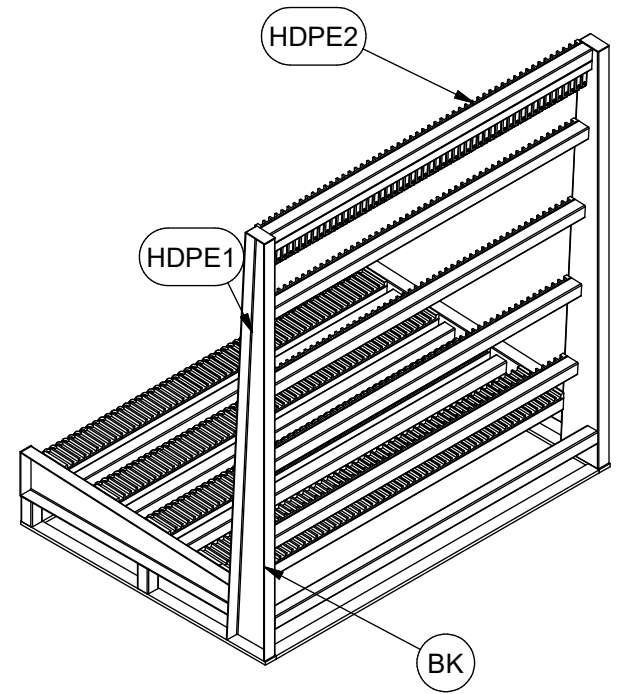
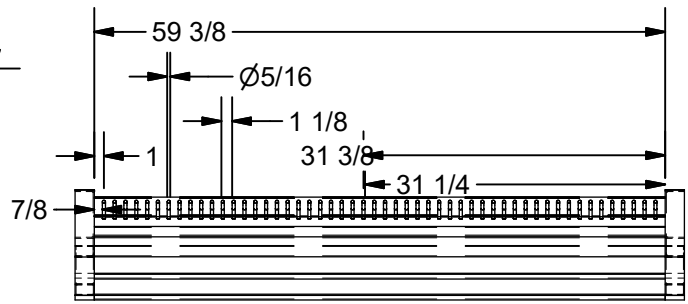
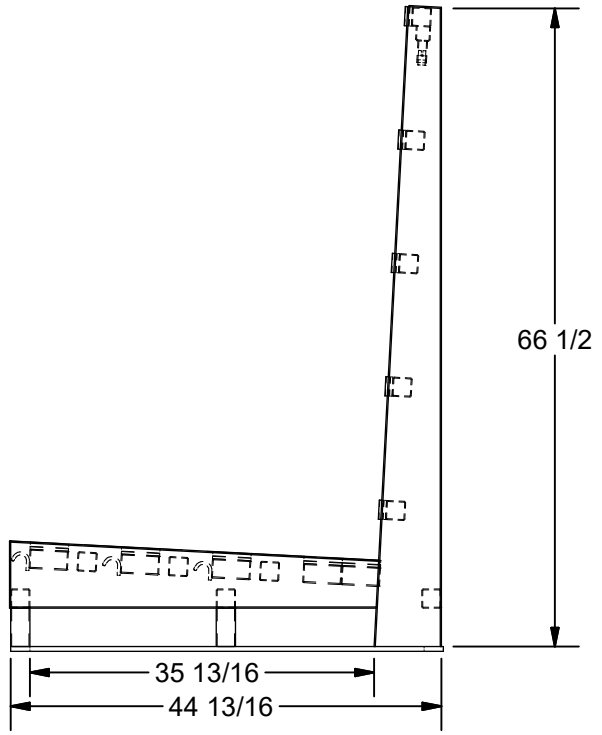

| QTY | ITEM  | DESCRIPTION | LENGTH    | QTY | ITEM  | DESCRIPTION | LENGTH    |
|-----|-------|-------------|-----------|-----|-------|-------------|-----------|
| 5   | HDPE2 | 3/4" HDPE   | 59 3/8 in | 1   | BS    |             |           |
| 1   | BCL   |             |           | 1   | BK    |             |           |
|     |       |             |           | 5   | HDPE1 | 3/4" HDPE   | 59 3/8 in |

|   |                  |                |  |
|---|------------------|----------------|--|
| Title:                                      |                  | Drawn By: Tony |  |
| File Name: K-11STGI 4' Deep                 | Job #: 240606    | Date:          |  |
| Customer: 1 3/5 IG Shipping Rack<br>PO#9225 |                  | Checked By:    |  |
| Description: K-11STGI IG Shipping Rack      |                  | Date:          |  |
| Scale:                                      | Sheet #: 3 of 15 |                |  |

This drawing is property of Kear Fabrication Inc. and may not be copied or modified without the express consent of Kear Fabrication Inc. All dimensions are in inches and are accurate to 1/16". Angles are accurate to 1/2°. Report all changes and/or errors to the Kear Fabrication Inc. Engineering Department.

**Kear Fabrication Inc.**  
 27 Vanley Crescent  
 North York, ON, Canada M3J 2B7  
 Tel: (416) 398-8666  
 Fax: (416) 398-9666

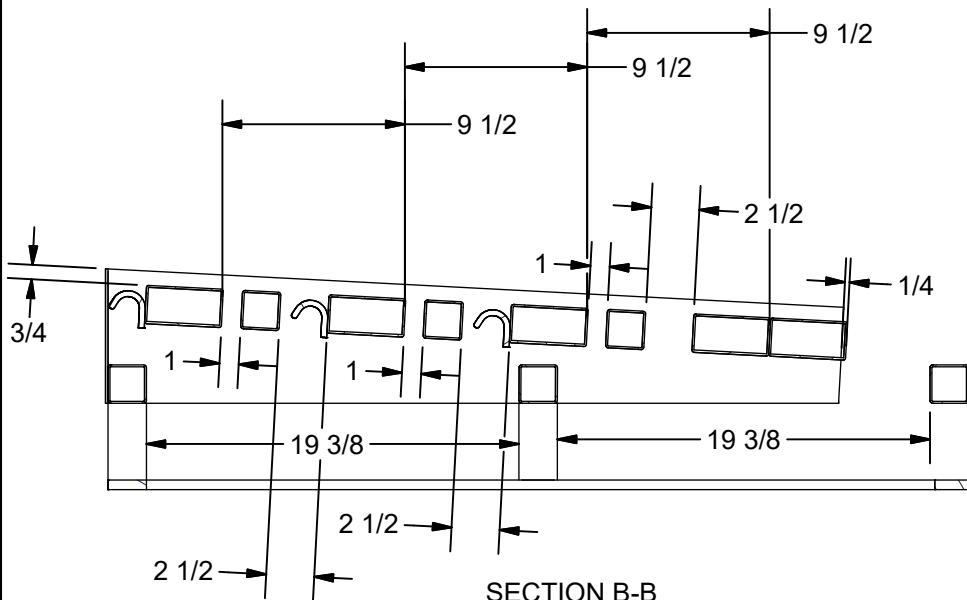
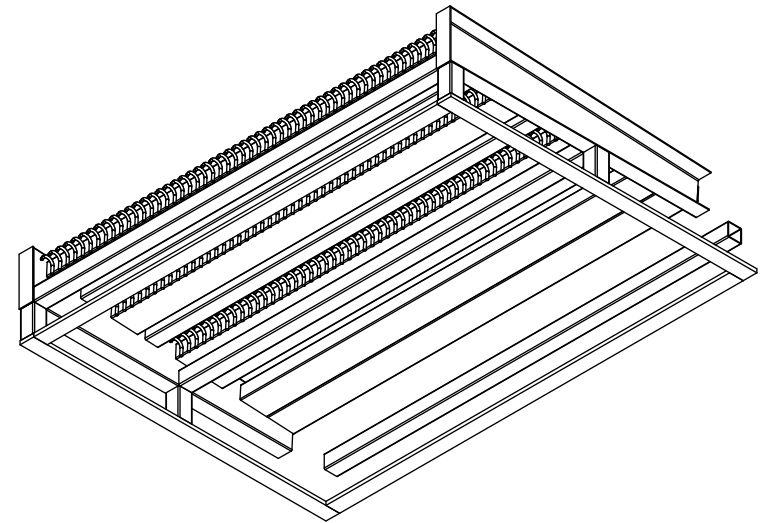
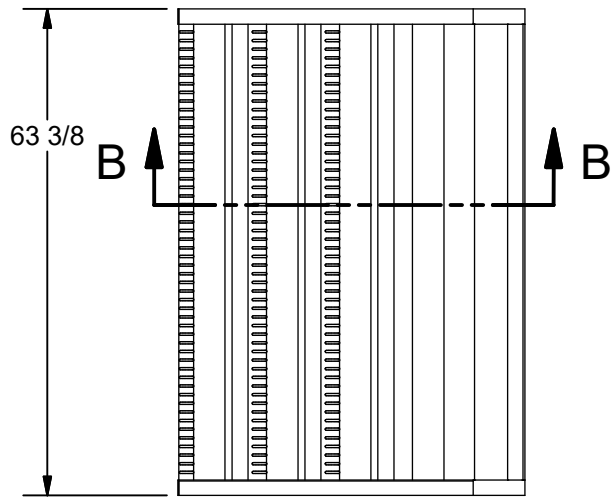

SECTION B-B  
SCALE 1 / 10

| QTY | ITEM | DESCRIPTION          | LENGTH    |
|-----|------|----------------------|-----------|
| 1   | BSL  | Base Form channel    |           |
| 1   | BSR  | Base Form channel    |           |
| 5   | 1    | 4"x2"x.125" Tube     | 59 3/8 in |
| 4   | 2    | 2" x 2" x .100" Tube | 4 in      |
| 6   | 3    | 2" x 2" x .100" Tube | 59 3/8 in |
| 2   | 4    | 1/2" x 2" Flat bar   | 45 in     |
| 2   | 5    | 1/2" x 2" Flat bar   | 59 3/8 in |
| 2   | 6    | 1/8" x 2" Flat bar   | 7 in      |
| 156 | 7    | 5/16" Rod Bend       | 3 1/2 in  |

|  |               |                  |        |   |  |
|--|---------------|------------------|--------|---|--|
| Title:                                 |               | Drawn By: Tony   |        | This drawing is property of Kear Fabrication Inc. and may not be copied or modified without the express consent of Kear Fabrication Inc. All dimensions are in inches and are accurate to 1/16". Angles are accurate to 1/2°. Report all changes and/or errors to the Kear Fabrication Inc. Engineering Department. | <b>Kear Fabrication Inc.</b><br>27 Vanley Crescent<br>North York, ON, Canada M3J 2B7<br>Tel: (416) 398-8666<br>Fax: (416) 398-9666 |
| File Name: Base No plastic             | Job #: 240606 | Date:            |        |   |  |
| Customer: PO#9225                      |               | Checked By:      |        |   |  |
| Description: K-11STGI IG Shipping Rack |               | Date:            | Scale: |   |  |
|  |               | Sheet #: 4 of 15 |        |   |  |

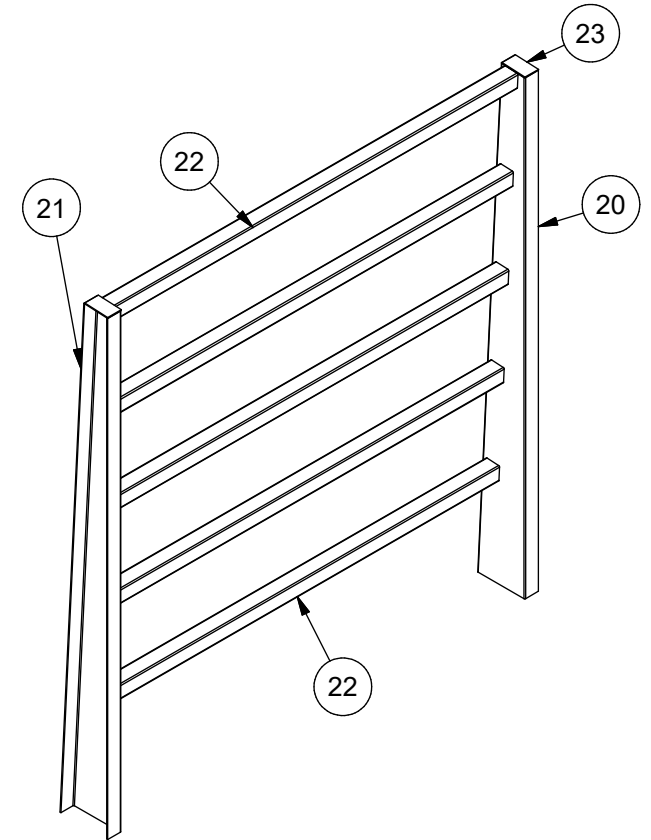
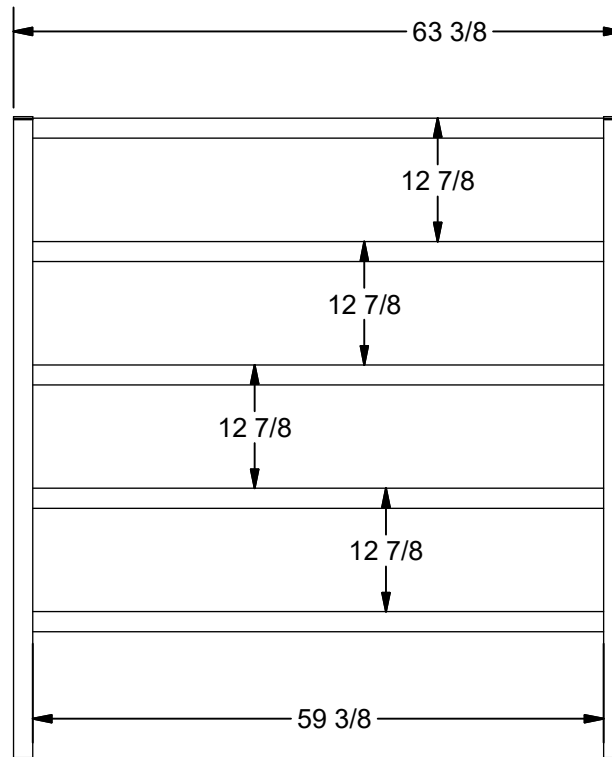
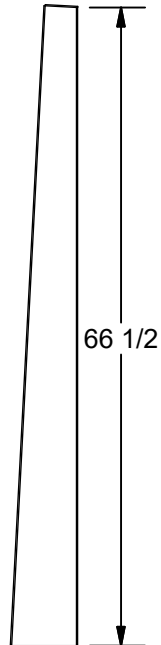

| QTY | ITEM | DESCRIPTION          | LENGTH    |
|-----|------|----------------------|-----------|
| 1   | 20   | Back Form Channel    |           |
| 1   | 21   | Back Form Channel    |           |
| 5   | 22   | 2" x 2" x .100" Tube | 59 3/8 in |
| 2   | 23   | 1/8" x 2" Flat bar   | 3 3/8 in  |

|  |               |                |                  |
|--|---------------|----------------|------------------|
| Title:                                 |               | Drawn By: Tony |                  |
| File Name: Back no plastic             | Job #: 240606 | Date:          |                  |
| Customer: PO#9225                      |               | Checked By:    |                  |
| Description: K-11STGI IG Shipping Rack |               | Date:          |                  |
|  |               | Scale:         | Sheet #: 5 of 15 |

This drawing is property of Kear Fabrication Inc. and may not be copied or modified without the express consent of Kear Fabrication Inc. All dimensions are in inches and are accurate to 1/16". Angles are accurate to 1/2°. Report all changes and/or errors to the Kear Fabrication Inc. Engineering Department.

**Kear Fabrication Inc.**  
 27 Vanley Crescent  
 North York, ON, Canada M3J 2B7  
 Tel: (416) 398-8666  
 Fax: (416) 398-9666

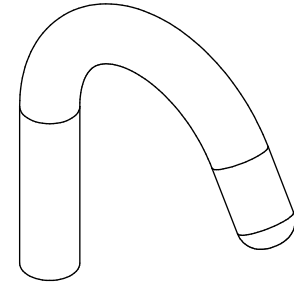
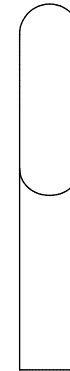
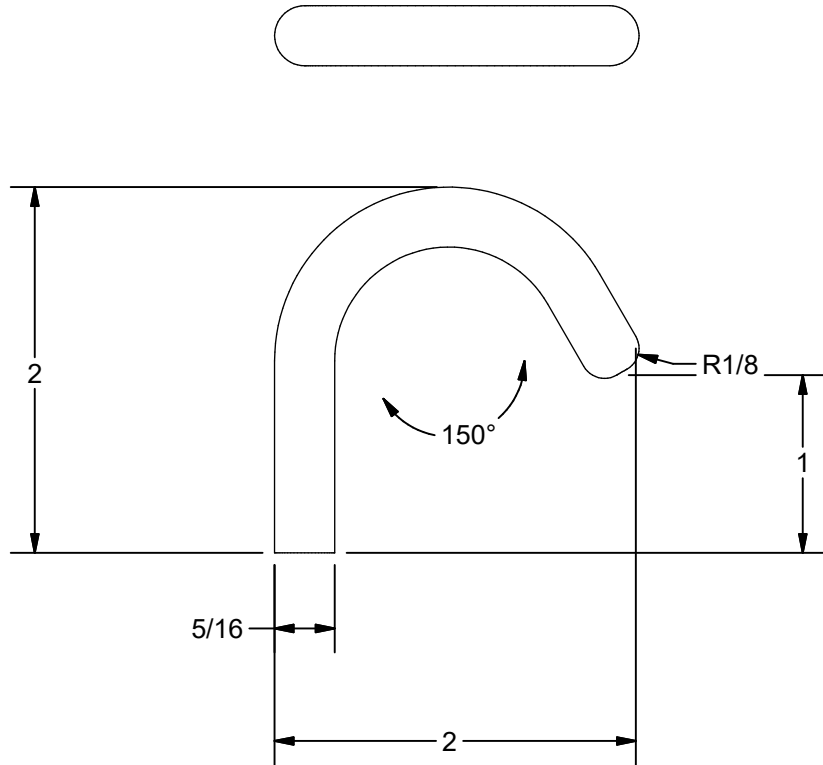

K-11STG Part#104  
 Material: 5/16" Rod  
 Quantity: 75 each rack

|  |               |                |                  |   |  |
|--|---------------|----------------|------------------|---|--|
| Title:                                 |               | Drawn By: Tony |                  | This drawing is property of Kear Fabrication Inc. and may not be copied or modified without the express consent of Kear Fabrication Inc. All dimensions are in inches and are accurate to 1/16". Angles are accurate to 1/2°. Report all changes and/or errors to the Kear Fabrication Inc. Engineering Department. | <b>Kear Fabrication Inc.</b><br>27 Vanley Crescent<br>North York, ON, Canada M3J 2B7<br>Tel: (416) 398-8666<br>Fax: (416) 398-9666 |
| File Name: 104                         | Job #: 240606 | Date:          |                  |   |  |
| Customer: PO#9225                      |               | Checked By:    |                  |   |  |
| Description: K-11STGI IG Shipping Rack |               | Date:          |                  |   |  |
|  |               | Scale:         | Sheet #: 6 of 15 |   |  |

Require: 5pcs

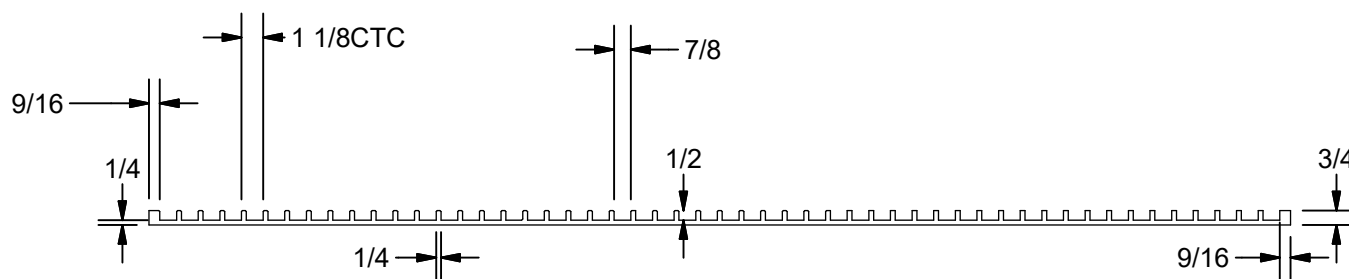
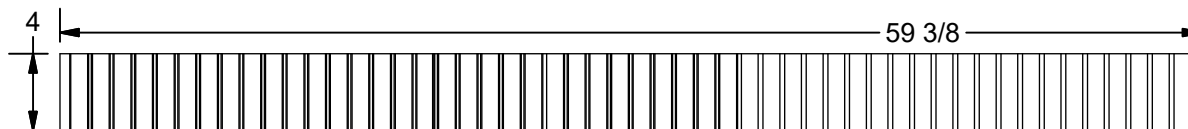
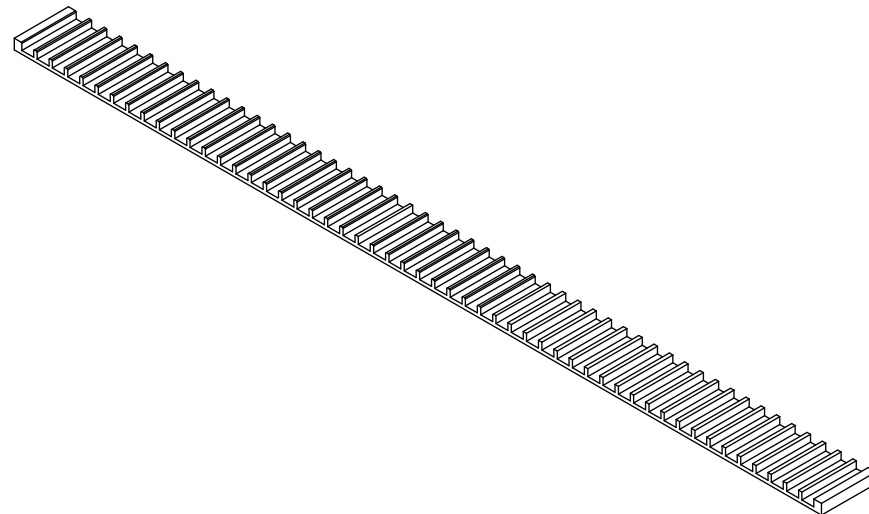

|  |                  |                |  |   |  |
|--|------------------|----------------|--|---|--|
| Title:                                 |                  | Drawn By: Tony |  | This drawing is property of Kear Fabrication Inc. and may not be copied or modified without the express consent of Kear Fabrication Inc. All dimensions are in inches and are accurate to 1/16". Angles are accurate to 1/2°. Report all changes and/or errors to the Kear Fabrication Inc. Engineering Department. | <b>Kear Fabrication Inc.</b><br>27 Vanley Crescent<br>North York, ON, Canada M3J 2B7<br>Tel: (416) 398-8666<br>Fax: (416) 398-9666 |
| File Name: 209Larg                     | Job #: 240606    | Date:          |  |   |  |
| Customer: PO#9225                      |                  | Checked By:    |  |   |  |
| Description: K-11STGI IG Shipping Rack |                  | Date:          |  |   |  |
| Scale:                                 | Sheet #: 7 of 15 |                |  |   |  |

Require: 5pcs

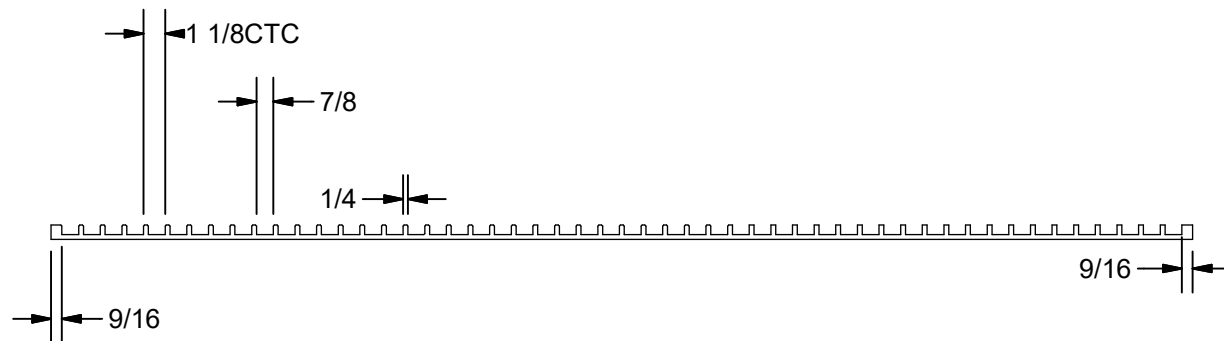
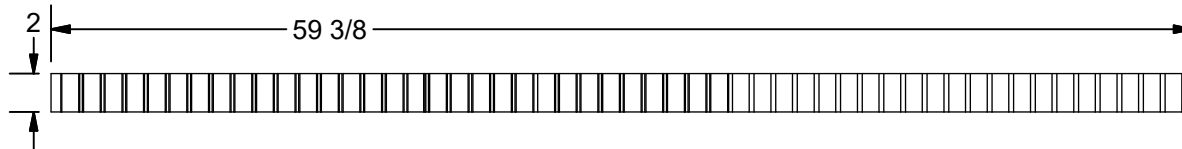
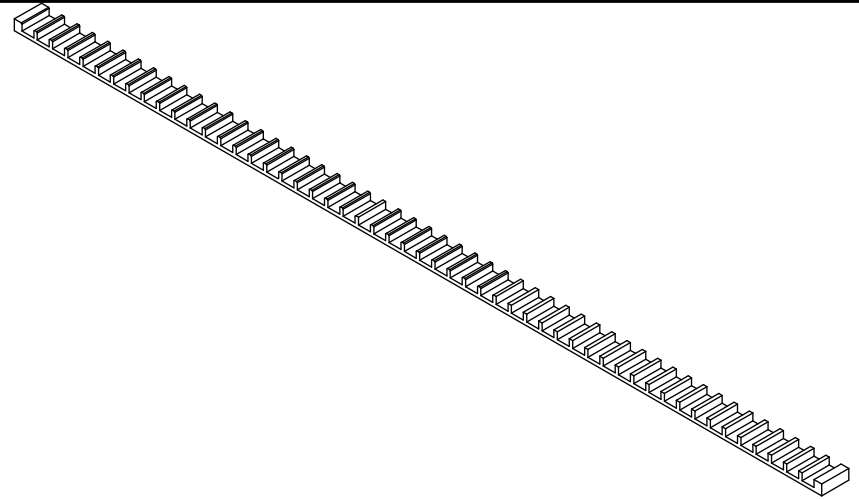

|  |               |                |                  |   |  |
|--|---------------|----------------|------------------|---|--|
| Title:                                 |               | Drawn By: Tony |                  | This drawing is property of Kear Fabrication Inc. and may not be copied or modified without the express consent of Kear Fabrication Inc. All dimensions are in inches and are accurate to 1/16". Angles are accurate to 1/2°. Report all changes and/or errors to the Kear Fabrication Inc. Engineering Department. | <b>Kear Fabrication Inc.</b><br>27 Vanley Crescent<br>North York, ON, Canada M3J 2B7<br>Tel: (416) 398-8666<br>Fax: (416) 398-9666 |
| File Name: 210Large                    | Job #: 240606 | Date:          |                  |   |  |
| Customer: PO#9225                      |               | Checked By:    |                  |   |  |
| Description: K-11STGI IG Shipping Rack |               | Date:          |                  |   |  |
|  |               | Scale:         | Sheet #: 8 of 15 |   |  |



K-11STGI Part#C01R-23799

Material: 10GA HR

Quantity: 20pcs

They both are the same but 1 left & 1 right hand

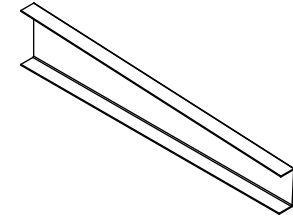
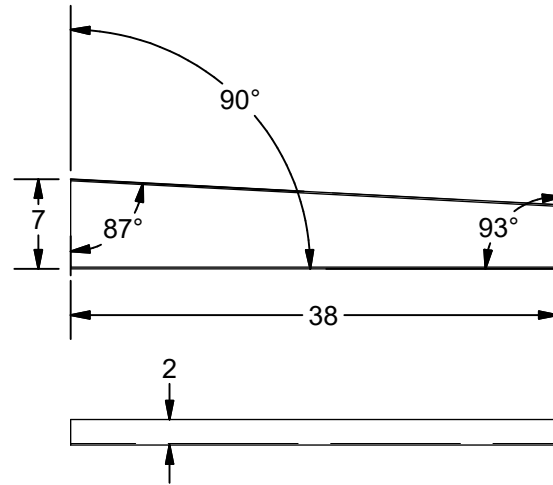

K-11STGI Part#C01L-23799

Material: 10GA HR

Quantity: 20pcs

They both are the same but 1 left & 1 right hand

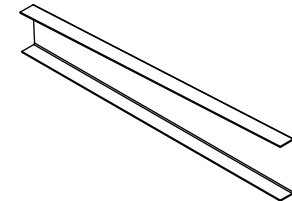
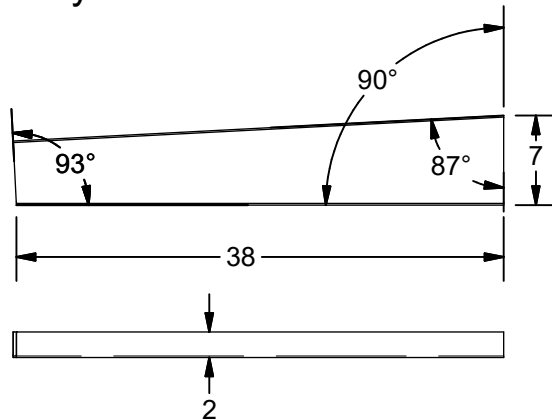

**K E A R** FABRICATION INC.

27 Vanley Crescent, North York, ON, M3J 2B7 - Tel: (416) 398-8666 - Fax: (416) 398-9666

This drawing is property of Kear Fabrication Inc. for Purpose of customer approval only. Any dimensions, materials, parts and paint not shown in the drawing are pending to standards and design of Kear Fabrication Inc.

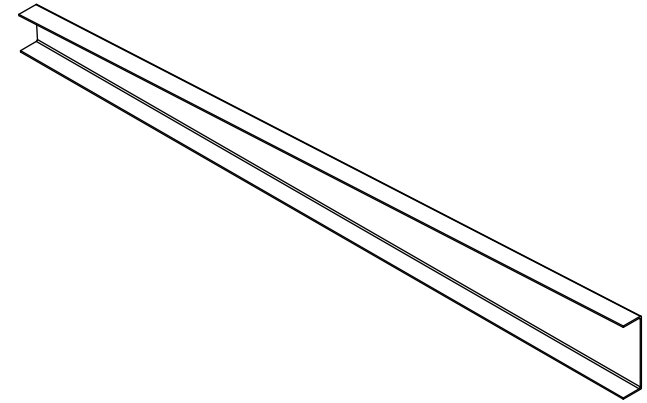
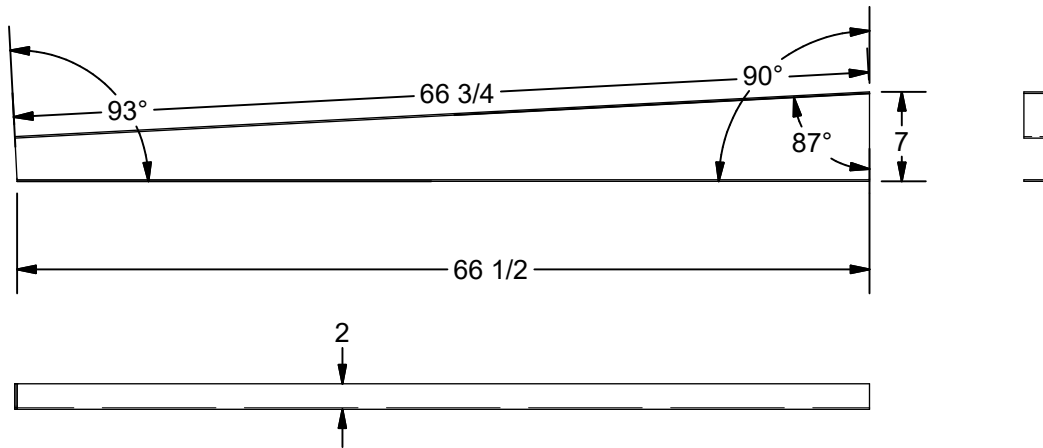

K-11STGI Part#C02R-23799

Material: 10GA HR

Quantity: 20pcs

They both are the same but 1 left & 1 right hand

K-11STGI Part#C02L-23799

Material: 10GA HR

Quantity: 20pcs

They both are the same but 1 left & 1 right hand

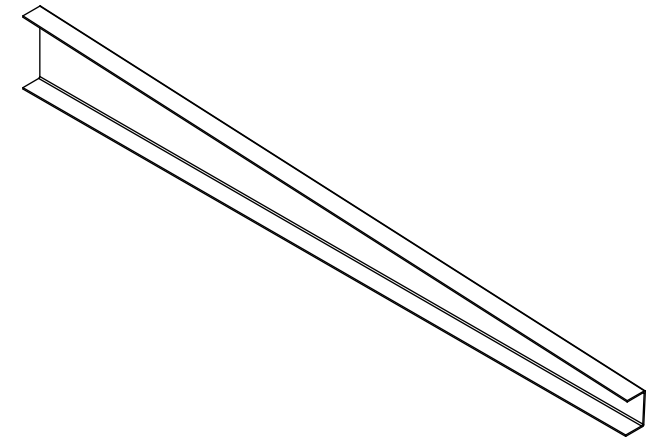
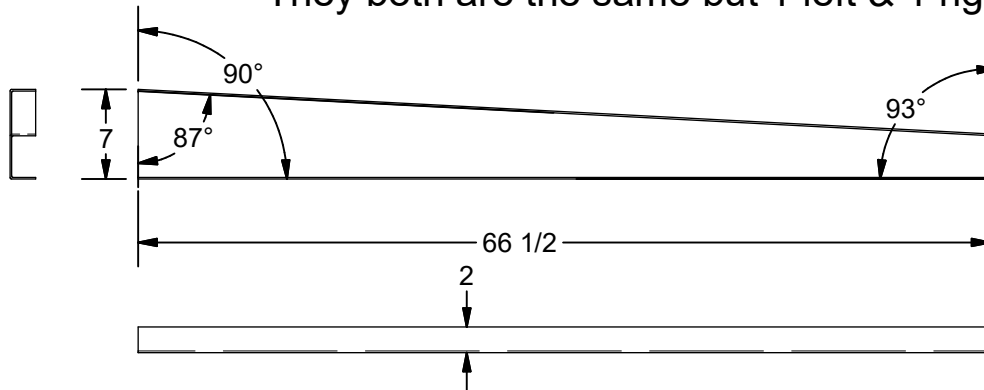

**K E A R** FABRICATION INC.  
27 Vanley Crescent, North York, ON, M3J 2B7 - Tel: (416) 398-8666 - Fax: (416) 398-9666

This drawing is property of Kear Fabrication Inc. for Purpose of customer approval only. Any dimensions, materials, parts and paint not shown in the drawing are pending to standards and design of Kear Fabrication Inc.

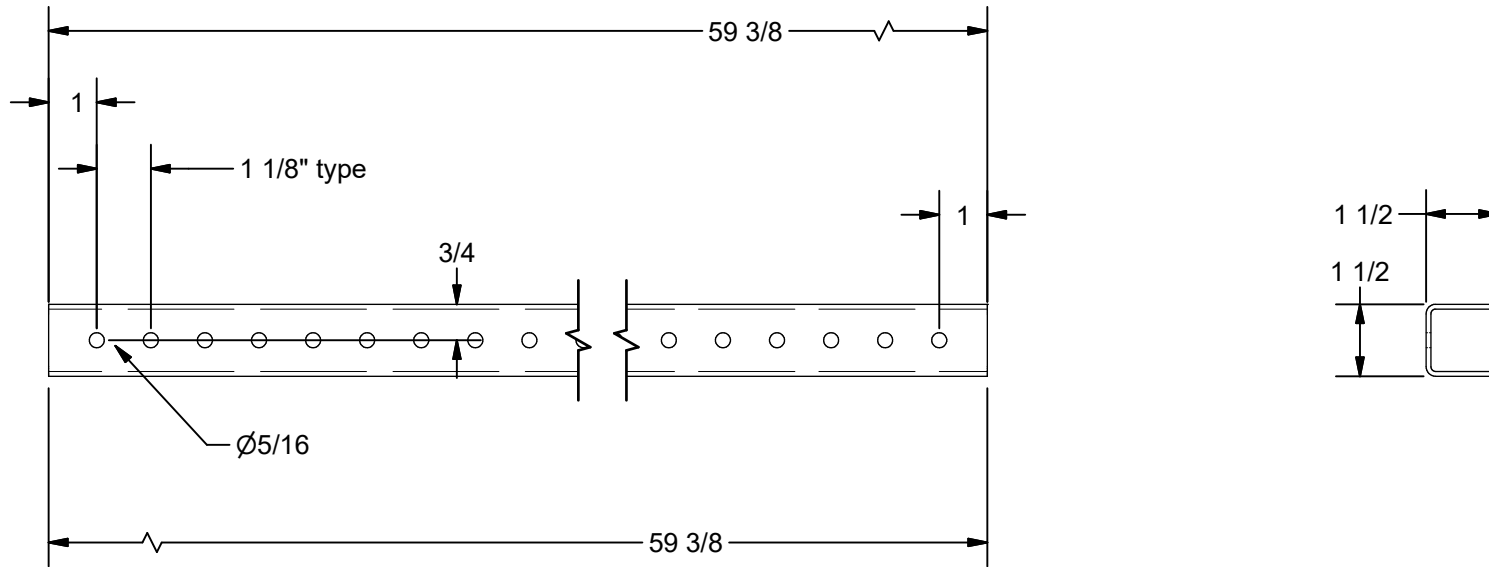

**K-11STGI Lock Cord Part#FC01-23799**

Material: 1.5" x 1.5" Form Channel

Material: 12GA HR

Require: 10pcs

**K E A R F A B R I C A T I O N I N C .**

27 Vanley Crescent, North York, ON, M3J 2B7 - Tel: (416) 398-8666 - Fax: (416) 398-9666

This drawing is property of Kear Fabrication Inc. for Purpose of customer approval only. Any dimensions, materials, parts and paint not shown in the drawing are pending to standards and design of Kear Fabrication Inc.

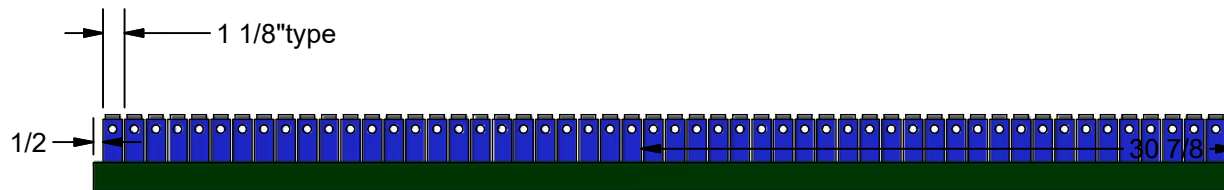
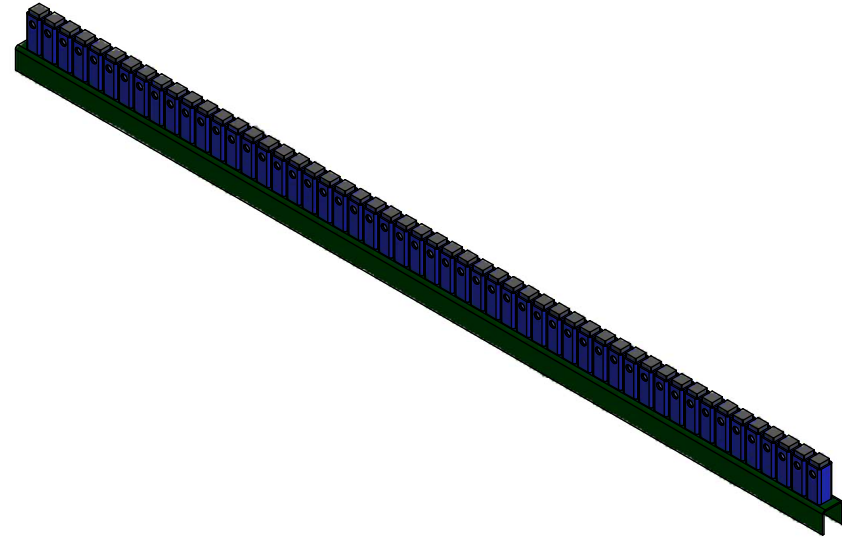

**K E A R** FABRICATION INC.  
27 Vanley Crescent, North York, ON, M3J 2B7 - Tel: (416) 398-8666 - Fax: (416) 398-9666

This drawing is property of Kear Fabrication Inc. for Purpose of customer approval only. Any dimensions, materials, parts and paint not shown in the drawing are pending to standards and design of Kear Fabrication Inc.

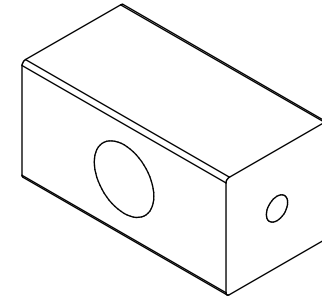
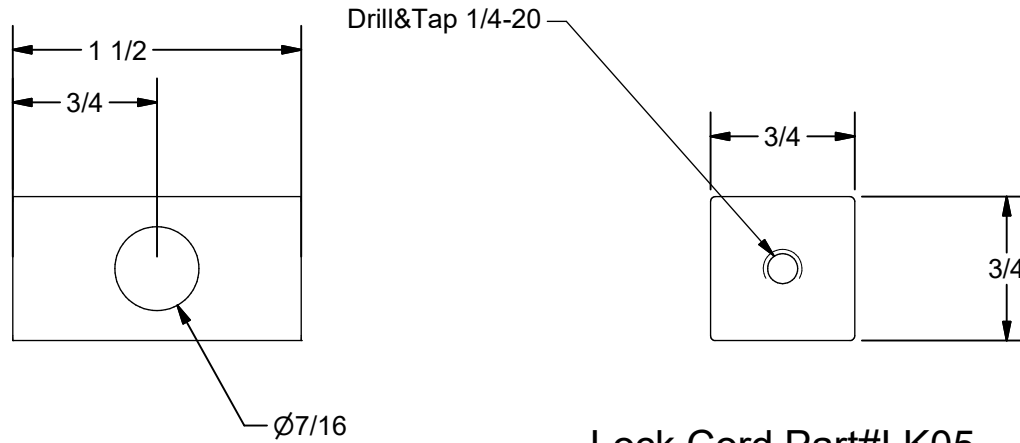

Lock Cord Part#LK05  
Material: 3/4" x 3/4" UHMW Square bar  
Require: 600pcs

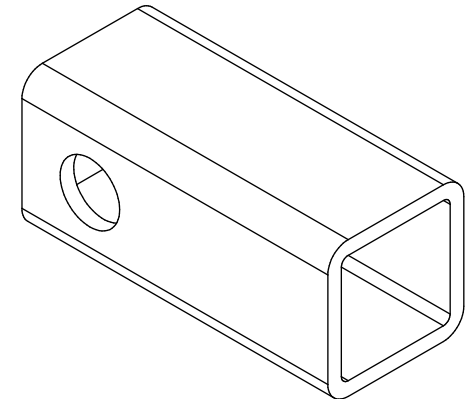
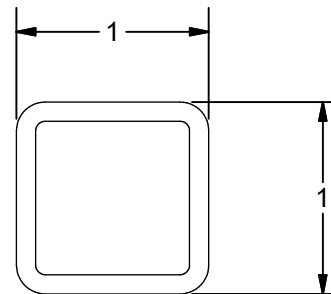
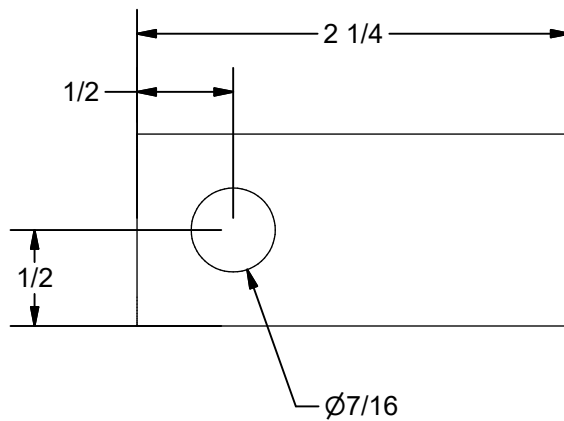

Lock Cord Part#LK06  
Material: 1" x 1" x 0.100" Tube  
Require: 600pcs

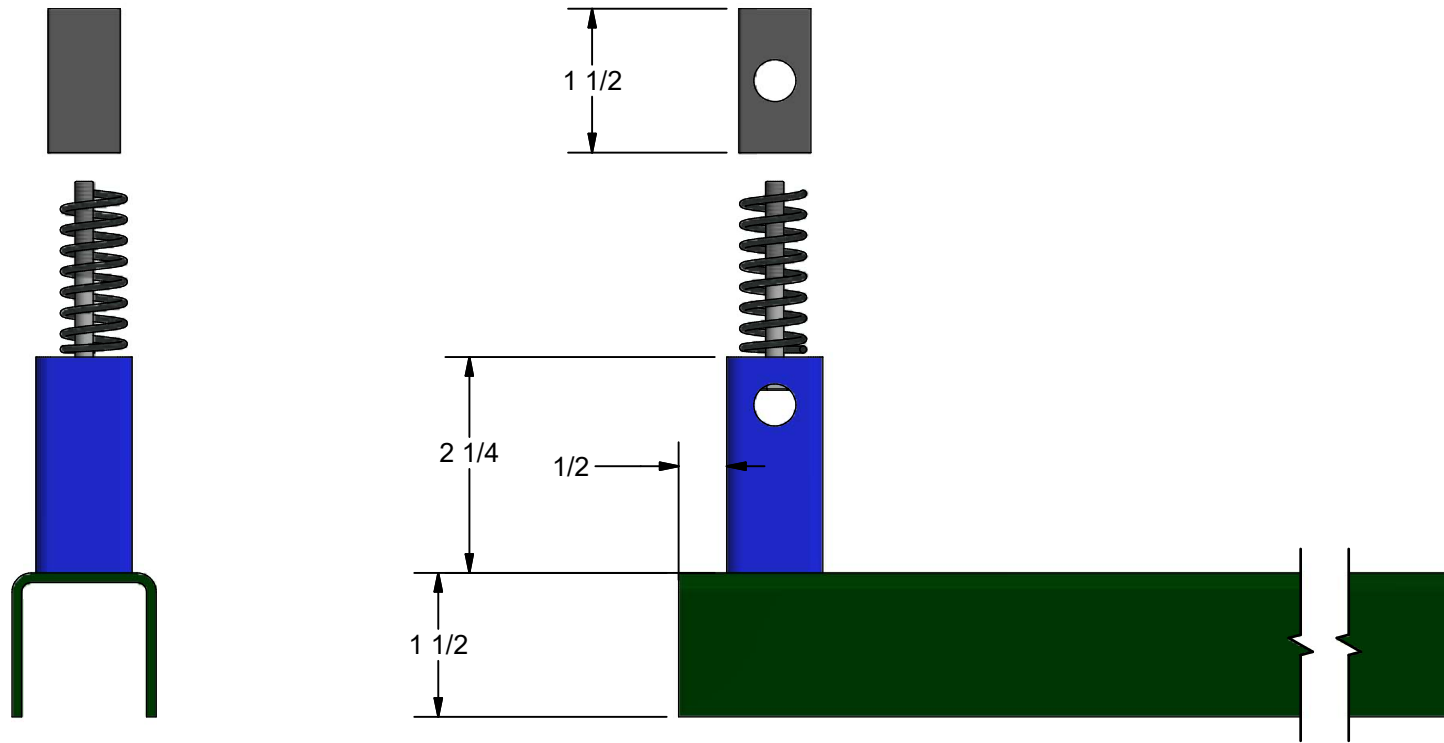

**K E A R** FABRICATION INC.  
27 Vanley Crescent, North York, ON, M3J 2B7 - Tel: (416) 398-8666 - Fax: (416) 398-9666

This drawing is property of Kear Fabrication Inc. for Purpose of customer approval only. Any dimensions, materials, parts and paint not shown in the drawing are pending to standards and design of Kear Fabrication Inc.

3/4" thick x 2" x 59-3/8" long (46@1" wide with 1/4" ride)

Require: 5pcs per rack

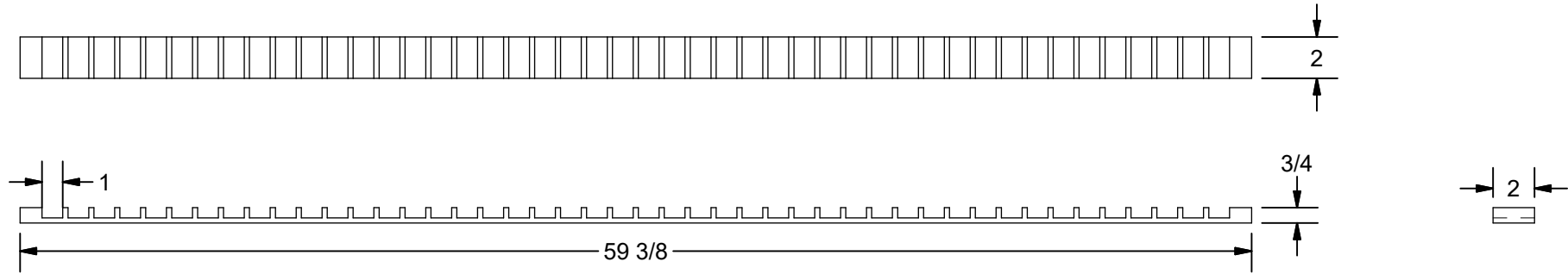

3/4" thick x 4" x 59-3/8" long (46@1" wide with 1/4" ride)

Require: 5pcs per rack

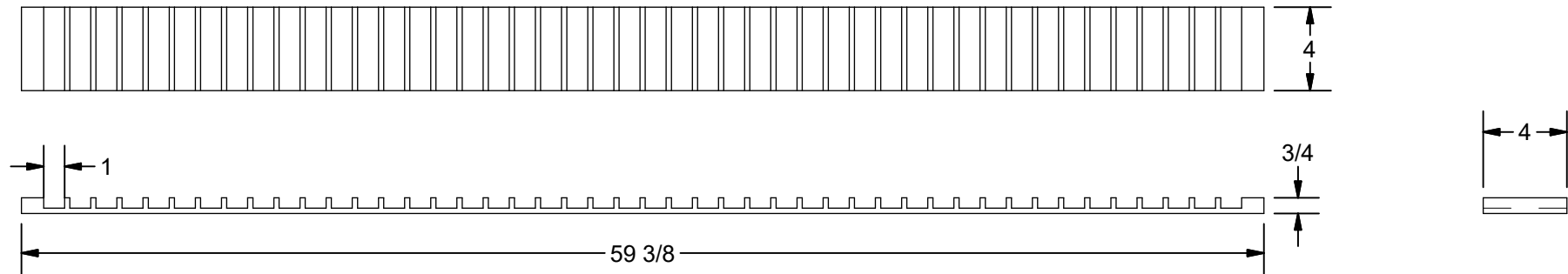

**K E A R FABRICATION INC.**

27 Vanley Crescent, North York, ON, M3J 2B7 - Tel: (416) 398-8666 - Fax: (416) 398-9666

This drawing is property of Kear Fabrication Inc. for Purpose of customer approval only. Any dimensions, materials, parts and paint not shown in the drawing are pending to standards and design of Kear Fabrication Inc.